

CleanSpace®

R E S P I R A T O R S

USER INSTRUCTIONS

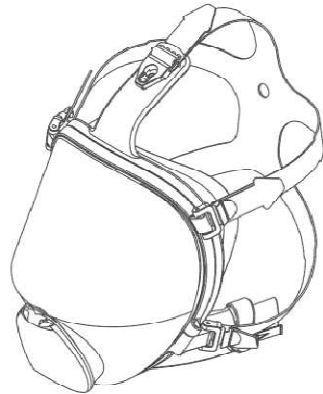
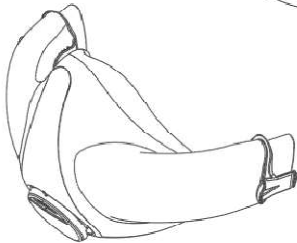
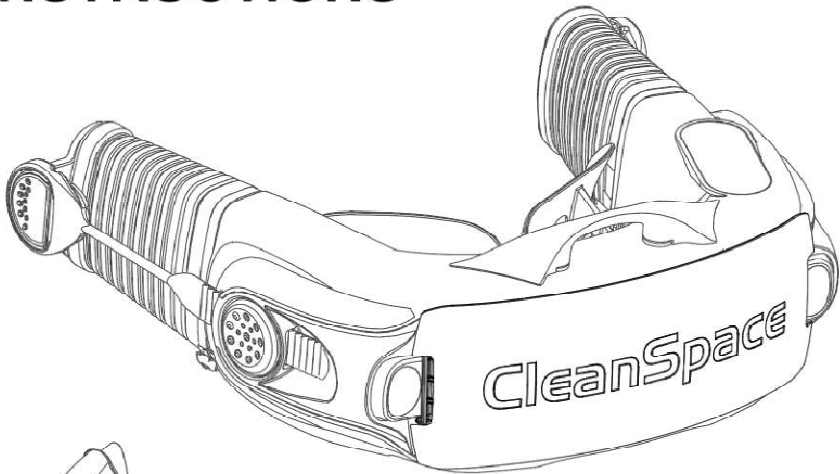

CleanSpace PRO CST1000

CleanSpace ULTRA CST1010

CleanSpace Technology Pty Ltd
ABN 24 146 453 554
T: +61 2 8436 4000

Unit 5, 39 Herbert Street
St. Leonards NSW 2065 Australia

www.cleanspacetechnology.com
sales@cleanspacetechnology.com

Contents

1.	Warnings & Limitations.....	3
1.1.	List of Warnings Within These User Instructions	3
1.2.	Limitations.....	4
1.3.	Manufacturers Minimum Design Condition (MMDC).....	5
1.4.	Special or Critical User Instructions.....	6
2.	System Description	6
2.1.	System Components	6
2.2.	Controls and Indicators.....	8
2.3.	Alarms	10
2.4.	Battery	11
2.5.	Filters.....	12
2.6.	Accessories	13
3.	Before Donning the CleanSpace Respirator	14
3.1.	CleanSpace Respirator Fit	14
3.2.	Pre-Use Inspection	15
3.3.	Recalibration	15
3.4.	Flow Test	16
4.	Donning the Half Mask CleanSpace Respirator	17
	Step 1 – Fit the Neck Support to the Power Unit.....	17
	Step 2 – Fit the Head Harness to the Half Mask.....	17
	Step 3 – Fit the Half Mask to the Power Unit.....	17
	Step 4 – Switch the Power Unit to STANDBY Mode.....	18
	Step 5 – Don the Respirator.....	18
	Step 6 – Adjust the Respirator	19
	Step 7 – Complete a Mask Seal Check	19
5.	Donning the Full-Face Mask CleanSpace Respirator.....	20
	Step 1 – Fit the Neck Support to the Power Unit.....	20
	Step 2 – Don the Full-Face Mask.....	20
	Step 3 – Complete a Mask Seal Check	21
	Step 4 – Switch the Power Unit to STANDBY Mode.....	21
	Step 5 – Don the Respirator.....	21
	Step 6 – Adjust the Respirator	22
6.	The Contaminated Area	22
6.1.	Human Factor Considerations.....	22
6.2.	Entering the Contaminated Area	23

6.3.	<i>Exiting the Contaminated Area</i>	23
6.4.	<i>Doffing the Half Mask Respirator</i>	23
6.5.	<i>Doffing the Full-Face Mask Respirator</i>	24
7.	Care and Cleaning	24
7.1.	<i>Cleaning</i>	24
7.2.	<i>Storage</i>	26
7.3.	<i>Recalibration</i>	26
7.4.	<i>Servicing</i>	26
8.	List of Components.....	26
9.	Specifications.....	27
10.	Warranty.....	28

Please take a moment to register for warranty of your CleanSpace Respirator at cleanspacetechnology.com/warranty-registration.

Before use, the wearer must read and understand the entirety of these User Instructions including all warnings, all additional information relating to the appropriate use of CleanSpace filters and accessories and all relevant information documented in national standards. If you have questions regarding this system, please contact CleanSpace Customer Service on [+612 8436 4000](tel:+61284364000) or e-mail support@cleanspacetechnology.com.



This product is part of a system that helps protect against certain airborne contaminants. Misuse may result in sickness. For proper use, consult an Occupational Health Specialist, these User Instructions or contact CleanSpace Technology Customer Support on support@cleanspacetechnology.com.

1. Warnings & Limitations

1.1. LIST OF WARNINGS WITHIN THESE USER INSTRUCTIONS

1.1.1 GENERAL

- This product is part of a system that helps protect against certain airborne contaminants. Misuse may result in sickness. For proper use, consult an Occupational Health Specialist, these User Instructions or contact CleanSpace Technology Customer Support on support@cleanspacetechnology.com.
- Properly selected, used and maintained respirators help to protect against certain airborne contaminants. It is essential to follow all instructions and government regulations on the use of this product, including wearing the complete respirator system during all times of exposure, in order for the product to help protect the wearer. Misuse of respirators may result in overexposure to contaminants and lead to sickness. For proper use, consult an Occupational Health Specialist, these User Instructions or contact CleanSpace Technology Customer Support on support@cleanspacetechnology.com or the website: cleanspacetechnology.com
- You must recalibrate the internal pressure sensor any time that your CleanSpace Respirator is exposed to changes in temperature of more than 20°C, changes in altitude of more than 100m or before using the respirator for the first time. It is best practice to also recalibrate if the unit has been in storage, particularly if the storage temperature is not known.

1.1.2 BATTERY

- Using the respirator after the Low Battery Alarm has triggered can cause the flow to fall below the minimum design flow. This may result in overexposure to contaminants and lead to sickness.

- Always correctly use and maintain the internal lithium-ion battery packs. Failure to do so may result in fire or explosion, or could adversely affect respirator performance and result in injury, sickness or death.
- CleanSpace PRO and CleanSpace ULTRA are not intrinsically safe. Do not use in flammable or explosive atmospheres. Doing so may result in injury or death.
- In the extremely rare circumstance that the battery is damaged and electrolyte comes in contact with eyes, flush with water immediately and seek urgent medical attention.
- The battery shall only be charged in non-hazardous areas. Move out of the hazardous area before charging. The Power Unit must not be placed on charge in enclosed cabinets without ventilation, near flammable liquids or gases or near heat sources. Do not use, charge or store the device outside the recommended temperature limits.
- CleanSpace Respirators use a unique charger. Do not attempt to charge your CleanSpace Respirator with any other charger.
- CleanSpace Power Units contain a battery, sensitive electronics, and a motor. NEVER immerse the Power Unit in water.

1.1.3 FILTER

- Using a filter that has exceeded service limits can cause the flow to fall below the minimum design flow. This may result in overexposure to contaminants and lead to sickness.
- Using the respirator without a filter installed will provide no respiratory protection. This may result in overexposure to contaminants and lead to sickness.
- Do not use compressed air or a brush to clean the filter. HEPA filters are very easily damaged by using compressed air or by brushing. Misuse of CleanSpace Respirators by cleaning the filter may result in overexposure to contaminants and lead to sickness.
- It is essential that the correct filter type is selected for the chosen application.
- Use only CleanSpace filters with the CleanSpace Respirator. Use of other filters may result in overexposure to contaminants and lead to sickness.

1.1.4 OPERATION

- Do not remove the respirator until you have left the contaminated area. If you have an acute and spontaneous health episode (i.e. experiencing dizziness) and believe removing the respirator while you leave the contaminated area may help, remove the respirator with caution.
- Never dry the mask or exhalation valve with a cloth that may leave behind lint. Lint contamination of the exhalation valve may cause it to leak, resulting in overexposure to contaminants and lead to sickness.



Throughout these User Instructions, this symbol will highlight important warnings.

1.2. LIMITATIONS

Use this respirator strictly in accordance with the information contained in these User Instructions. Never modify or alter this product.

1.2.1 CLEANSAPCE RESPIRATOR LIMITATIONS

- Please refer to your local standards and your workplace guidelines to determine the respiratory protection equipment that is most suited to your workplace and your needs.
- This respirator, when used with the Half Mask, does not protect your eyes. In conditions that may damage or irritate eyes, use protective eyewear.
- Only use your respirator with approved parts and accessories.
- Do not use the respirator unless it is powered and running normally.
- Do not use the respirator while it is being charged.
- Do not use in airborne contaminant concentrations above those specified in your national regulations.

- Do not use for respiratory protection against unknown atmospheric contaminants or when concentrations of contaminants are unknown or immediately dangerous to life or health (IDLH).
- Do not use in oxygen deficient or oxygen enriched atmospheres. Do not use in flammable or explosive environments.
- Only for use by trained personnel.
- Filters need to be changed regularly. The frequency of change depends on use and the concentration of contaminants in the atmosphere.
- Do not use for escape purposes. National regulations may impose specific limitations on the use of filters depending on the filter class and the facemask used.
- If the respirator has been used in an area that has caused it to become contaminated with a substance requiring special decontamination procedures it should be placed in a suitable container and sealed until it can be decontaminated.
- Do not disassemble the respirator case. There are no user serviceable parts inside.
- Failure to follow all instructions on the use of this product, and/or failure to use the respirator during times of exposure, may lead to adverse effects on the wearer's health and may render the warranty void.

1.2.2 IMMEDIATE EVACUATION

Leave the contaminated area immediately if any of the following occurs.

- The respirator warning lights and/or sounds activate for the Low Battery Alarm, Filter Absent Alarm or the Filter Change Alert.
- Any part of the respirator is damaged.
- Airflow into the mask decreases or stops.
- Breathing becomes difficult or increased resistance occurs.
- You feel dizzy or your airway is irritated.
- You can taste or smell contaminants.

1.2.3 OPERATING CONDITIONS

Your respirator is suitable for use in the following atmospheric conditions.

- **Temperature:** -10°C to 45°C.
- **Relative humidity:** 0 to 90% non-condensing.

The respirator will stop functioning if its internal temperature rises above 60°C or falls below -10°C.

If using the respirator at an altitude greater than 200m above sea level or less than 0m, make sure the operating altitude is set correctly before use. The operating altitude can be set by recalibrating the Power Unit (see Section 3.3).



This product is part of a system that helps protect against certain airborne contaminants. Misuse may result in sickness. For proper use, consult an Occupational Health Specialist, these User Instructions or contact CleanSpace Technology Customer Support on support@cleanspacetechnology.com.

1.3. MANUFACTURERS MINIMUM DESIGN CONDITION (MMDC)

In worst-case conditions (very low battery, heavily clogged filter) your respirator will maintain positive pressure in the mask with an associated flow rate of 120 l/min. This is the manufacturer's minimum design condition (MMDC). Fully charged, with a clean particulate filter, it will maintain positive pressure in the mask with an associated flow rate above 200 l/min.

The manufacturers claimed duration when operated at the MMDC is 4 hours. This is the minimum run time a user should expect from the respirator. In normal use, run times of up to 12-14 hours are more common. Run times are heavily influenced by altitude, filter condition, filter type, work rate, mask seal and other factors.

To confirm that your respirator can perform above the MMDC prior to use, run the Flow Test as described in Section 3.4.

1.4. SPECIAL OR CRITICAL USER INSTRUCTIONS

This respirator contains a system for synchronizing with your breathing, regulating mask pressure and updating the operating altitude of the Power Unit. This system should be recalibrated if it experiences a change in temperature of more than 20°C, a change in altitude of more than 100m or before using the respirator for the first time. It is best practice to also recalibrate if the unit has been in storage, particularly if the storage temperature is not known.

For the most accurate battery charge indication, the respirator must be plugged into its charger and the charger must be plugged into a power source. Wait for all three (3) Battery Charge Indicators to light solidly without flashing. If the third Battery Charge Indicator is flashing rapidly, the battery is 95% charged.

2. System Description

CleanSpace™ PRO (CST1000) and CleanSpace™ ULTRA (CST1010) are EN 12942 and AS/NZS 1716 approved respiratory systems which help to provide protection against particulates, gases and vapours. CleanSpace Respirators are Powered Air Purifying Respirators (PAPRs) which means that they draw ambient air through the filter using a fan and supply the filtered air to the wearer via the mask. The fan produces enough flow to ensure that the pressure inside the mask is positive, which helps to provide a high level of protection to the user. CleanSpace Respirators are breath responsive, which means that they provide more flow during inhalation and less flow during exhalation whilst maintaining positive pressure in the mask.



Properly selected, used and maintained respirators help to protect against certain airborne contaminants. It is essential to follow all instructions and government regulations on the use of this product, including wearing the complete respirator system during all times of exposure, in order for the product to help protect the wearer. Misuse of respirators may result in overexposure to contaminants and lead to sickness. For proper use, consult an Occupational Health Specialist, these User Instructions or contact CleanSpace Technology Customer Support on support@cleanspacetechnology.com or the website: cleanspacetechnology.com.

2.1. SYSTEM COMPONENTS

Throughout these User Instructions, reference is made to various commonly used components and features of the respirator. Familiarize yourself with these parts before reading the rest of the User Instructions. For a list of components and their respective part numbers refer to Section 8.

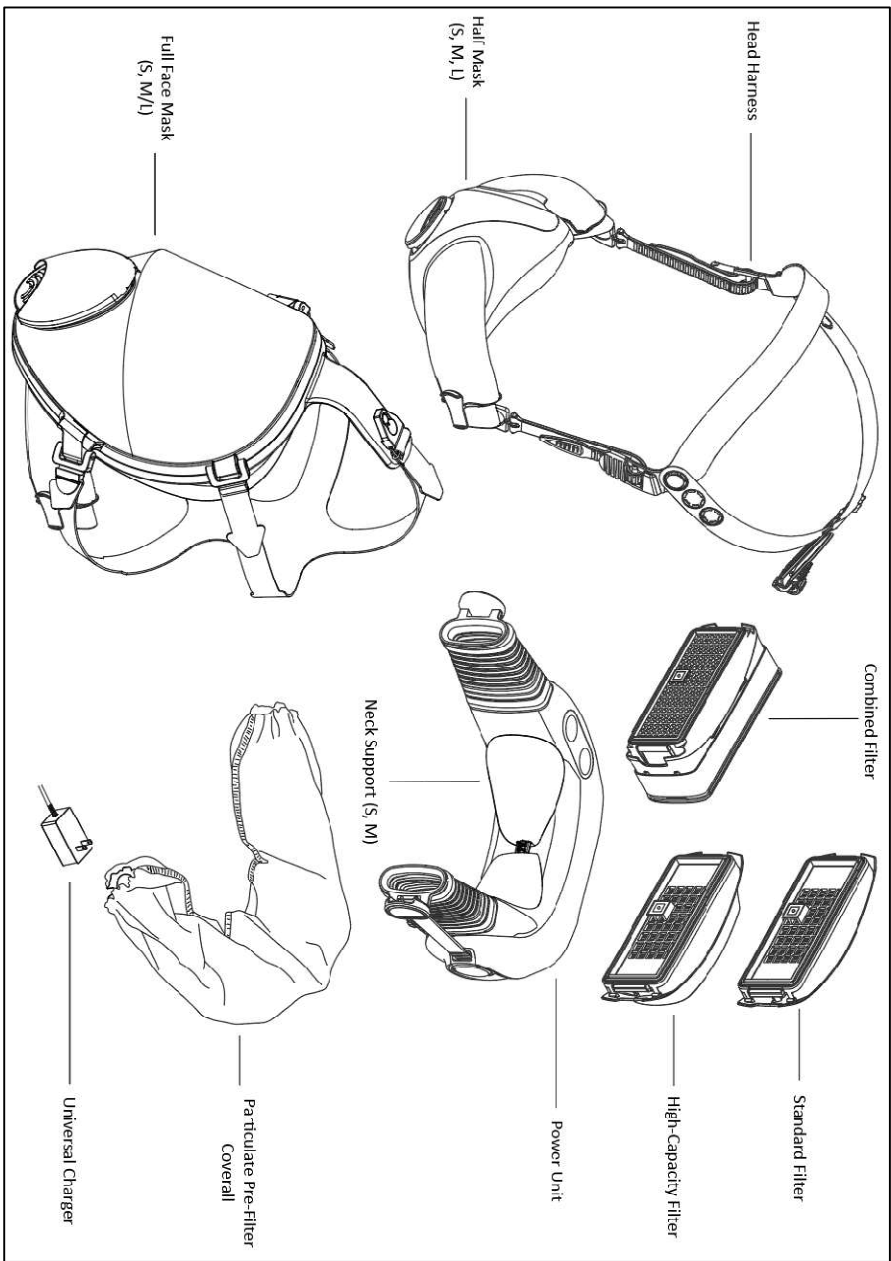

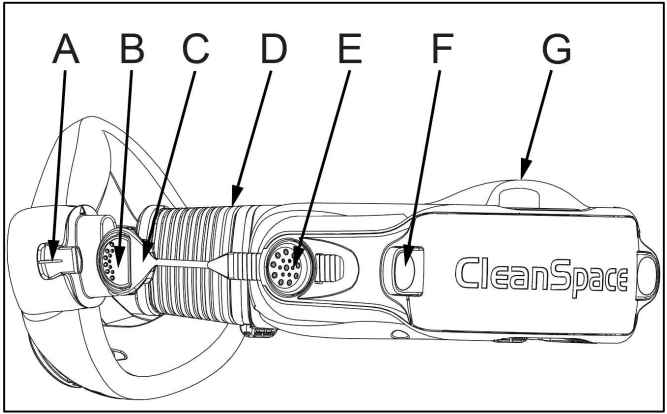

- A. Mask AirClip
- B. Mask Release Button
- C. Power Unit AirClip
- D. Bellow
- E. Adjust Button
- F. Filter Release Button
- G. Power Unit Hoop

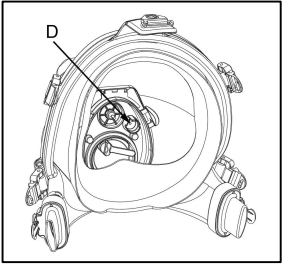
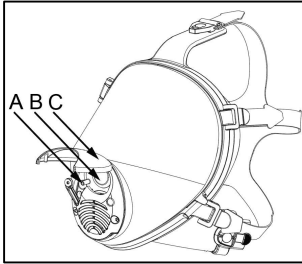

- A. Fit Test Port
- B. Exhalation Valve
- C. Rain Cover
- D. Sensing Ball Port

2.2. CONTROLS AND INDICATORS

2.2.1 KEYPAD

A keypad is located on the top of the Power Unit. It contains all controls and indicators.

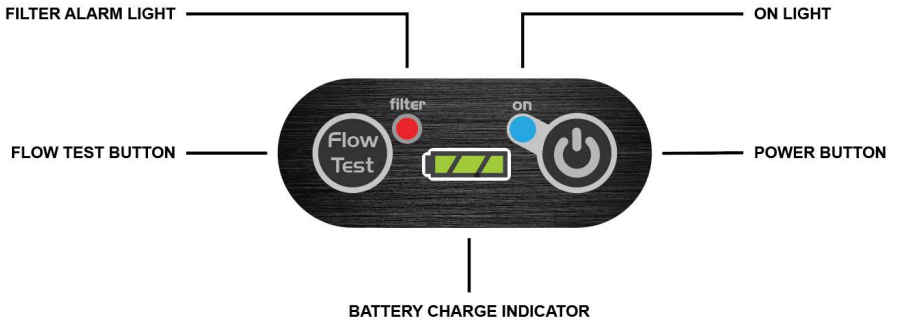

2.2.2 POWER BUTTON

The Power Button is used to switch the operating mode of the CleanSpace Respirator. There are three operating modes.

OFF Mode

The CleanSpace Respirator is unpowered.

The Battery Charge Indicator is not illuminated.

There is no airflow to the mask.

In OFF Mode, pressing the Power Button once will switch the CleanSpace Respirator to STANDBY Mode.

Note: The Power Button cannot be used to switch the Power Unit to OFF Mode.

STANDBY Mode

The CleanSpace Respirator is actively monitoring and ready to deliver filtered air to the mask with any pressure change.

The Battery Charge Indicator displays battery charge.

There is no airflow to the mask.

In STANDBY Mode, if breathing is detected the CleanSpace Respirator will automatically switch to ON Mode.

In STANDBY Mode, if no breathing is detected for 3 minutes, the CleanSpace Respirator will switch to OFF Mode. This conserves battery life.

Note: From STANDBY Mode, pressing the Power Button will switch the system to ON Mode. This is not normal procedure.

ON Mode

The CleanSpace Respirator is actively monitoring and delivering filtered air to the mask.

The Battery Charge Indicator displays battery charge.





The blue On Light is illuminated, indicating the Power Unit is in ON Mode.

In ON Mode, if no breathing is detected within 5 seconds, the CleanSpace Respirator will automatically switch to STANDBY Mode. This conserves battery life when not being worn.

CleanSpace Respirators can only switch to ON Mode from STANDBY Mode.

2.2.3 BATTERY CHARGE INDICATOR

A Battery Charge Indicator is located on the keypad of all CleanSpace Respirators. It is comprised of three green lights. The battery is fully charged when the charger is connected to the Power Unit and all three lights are solid green. The battery charge and approximate useful time remaining when the CleanSpace Respirator is NOT on charge are shown below.

Battery Charge Indicator	Battery Charge (%)	Approximate Useful Time Remaining (hrs)*
 3 Green Solid Lights	80 – 100 %	Up to 14 hours
 2 Green Solid Lights	50 – 80 %	6 – 10 hours
 1 Green Solid Light	20 – 50 %	2 – 6 hours
 1 Green Flashing Light	5 – 20 %	< 2 hours
 1 Green Flashing Light and Low Battery Alarm	< 5 %	< 15 minutes (Leave contaminated area immediately)
 Unpowered	0 %	0 minutes (non-normal operation)

**Operating time is strongly affected by filter type, filter loading, mask seal, work rate, altitude, and other factors. The operating times quoted above are average durations at moderate work rates at sea level. Actual operating times may vary widely from the quoted average durations.*

2.2.4 FLOW TEST BUTTON

The Flow Test measures the rate of flow produced by the CleanSpace Respirator to ensure it can deliver a minimum design flow of 120 l/min. When CleanSpace Respirators are in STANDBY Mode, pressing the Flow Test Button initiates the Flow Test.

Refer to Section 3.4 for instructions on running the flow test.

2.3. ALARMS

2.3.1 FILTER CHANGE ALERT

The Filter Change Alert:

- Is triggered when the filter exceeds service limits and needs to be changed.
- Consists of a repeated aural alert of two beeps per second and a red flashing Filter Alarm Light.
- Can be muted by pressing the Power or Flow Test Button once. Unless the filter is changed, the alert will resume when the CleanSpace Respirator next switches to STANDBY Mode.
- If the Filter Change Alert is triggered but the filter is still new, make sure the operating altitude is set correctly. The operating altitude can be set by recalibrating the Power Unit.

If the Filter Change Alert is triggered, the filter has exceeded service limits and should be changed.



Using a filter that has exceeded service limits can cause the flow to fall below the minimum design flow. This may result in overexposure to contaminants and lead to sickness.

2.3.2 LOW BATTERY ALARM

The Low Battery Alarm:

- Is triggered when the battery charge decreases below the level at which it may be able to supply the minimum design flow of 120 l/min.
- Consists of a repeated aural alert of three beeps per second and one green flashing Battery Charge Indicator light.
- Cannot be muted.

If the Low Battery Alarm is triggered, you must leave the contaminated area IMMEDIATELY and recharge the battery.



Using the respirator after the Low Battery Alarm has triggered can cause the flow to fall below the minimum design flow. This may result in overexposure to contaminants and lead to sickness.

2.3.3 FILTER ABSENT ALARM

The Filter Absent Alarm:

- Is triggered when the respirator is in ON Mode and it detects that there is no filter present.
- Consists of a continuous aural alert and a red flashing Filter Alarm Light.
- Can be muted by pressing the Power or Flow Test Button once. Unless a filter is inserted, the alarm will resume in one minute.

If the Filter Absent Alarm is triggered, you must install a filter before entering the contaminated area.



Using the respirator without a filter installed will provide no respiratory protection. This may result in overexposure to contaminants and lead to sickness.

2.4. BATTERY

CleanSpace Respirators have an internal lithium ion (Li-ion) battery. Lithium ion (Li-ion) batteries have the highest energy density of all battery types and are widely used in portable electronic devices. CleanSpace Respirators use quality Li-ion batteries and are designed to be viable over a minimum of 500 complete charge and discharge cycles while still maintaining at least 70% of their specified full capacity. For detailed battery information refer to the Product Information section of the CleanSpace website cleanspacetechnology.com.

2.4.1 BATTERY PRECAUTIONS

The following precautions must be followed during use:

- Avoid mechanical shocks or impacts from any sharp or hard objects.
- Do not use the respirator if there are any signs of severe mechanical damage.
- Do not use or place the respirator in extreme heat, such as in direct sunlight, near heat sources, etc. The battery will be damaged if its temperature rises above 70°C. The respirator will stop functioning if its internal temperature rises above 60°C or falls below -10°C. Do not use, charge or store the device outside the recommended temperature limits.
- Do not dispose of the respirator in a fire.
- Do not use the respirator in heavy rain or allow it to get wet or immersed in liquid.
- Do not disassemble the Power Unit case. Disassembly will void the Manufacturer's Warranty. There are no user serviceable parts inside.



Always correctly use and maintain the internal lithium-ion battery packs. Failure to do so may result in fire or explosion, or could adversely affect respirator performance and result in injury, sickness or death.



CleanSpace PRO and CleanSpace ULTRA are not intrinsically safe. Do not use in flammable or explosive atmospheres. Doing so may result in injury or death.



In the extremely rare circumstance that the battery is damaged and electrolyte comes in contact with eyes, flush with water immediately and seek urgent medical attention.

2.4.2 CHARGING THE BATTERY

The battery can only be charged at temperatures between 0°C and 35°C, should not be charged in electromagnetic environments (such as near welding machines) and should not be worn while being charged. To charge the battery.

1. Locate the charging port on the underside of the Power Unit.
2. Ensure the Universal Charger is plugged into a power source.
3. Insert the charger cable connector into the charging port.
4. Charging is indicated by at least one green flashing light on the Battery Charge Indicator.
5. When fully charged, three green solid lights will display on the Battery Charge Indicator.
6. If the third green Battery Charge Indicator light is flashing rapidly, charging is 95% complete.
7. When the Power Unit is charged, disconnect the charger cable from the charging port.

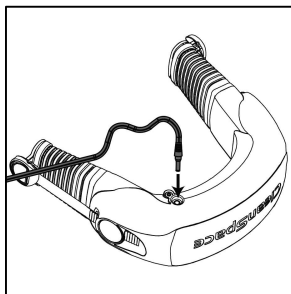

IMPORTANT: To ensure the battery is 100% charged, ensure the charger is connected to the Power Unit and the Battery Charge Indicator lights all turn on solid green (no flashing).



The battery shall only be charged in non-hazardous areas. Move out of the hazardous area before charging. The Power Unit must not be placed on charge in enclosed cabinets without ventilation, near flammable liquids or gases or near heat sources. Do not use, charge or store the device outside the recommended temperature limits.



CleanSpace Respirators use a unique charger. Do not attempt to charge your CleanSpace Respirator with any other charger.

2.5. FILTERS

2.5.1 FILTER PRECAUTIONS

The following precautions must be followed during use:

- Always change the filter outside of the contaminated area and with the respirator doffed.
- CleanSpace filter media cannot be cleaned. Cleaning the filter media may cause damage. The filter media is contained within a filter case. The filter case may be wiped with a dry cloth free of chemicals.
- Used filters should be disposed of responsibly and treated as non-recyclable hazardous waste (dependent on the contaminant being filtered).
- Change the filter if it is damaged or there is suspected damage.
- Filters should be changed regularly. The frequency of filter replacement depends on several factors: period of use, concentration of airborne contaminants, exertion levels and workplace protocols where hazards present a risk for cross contamination (e.g. biohazards or asbestos).



Do not use compressed air or a brush to clean the filter. HEPA filters are very easily damaged by using compressed air or by brushing. Misuse of CleanSpace Respirators by cleaning the filter may result in overexposure to contaminants and lead to sickness.



It is essential that the correct filter type is selected for the chosen application.



Use only CleanSpace filters with the CleanSpace Respirator. Use of other filters may result in overexposure to contaminants and lead to sickness.

2.5.2 CHANGING THE FILTER

Change the filter when:

- The Filter Change Alert triggers – audible (2 beeps per second) and visual (red Filter Alarm Light flashes).
- The Filter Absent Alarm triggers but there is a filter in place.
- The battery is fully charged and the operating altitude is set correctly, but the Flow Test indicates that the respirator is not able to produce the minimum design flow of 120 l/min.
- The filter has been exposed to water or other liquids.
- The outside of the filter case is heavily soiled.
- There is any sign of damage or suspected damage to the filter.
- The filter reaches its expiry date. The expiry date is marked on the filter label.

- There are signs of dust or contaminants on the inside surface of the filter.

A CleanSpace Respirator with a clean filter will run for much longer than one with a filter that contains dust contaminants. To maximize your work time between battery charges, change the filter often in high dust environments.

To remove a used filter, simply press down on either Filter Release Button (refer to Section 2.1) and the filter will be released. To install a new filter, align the filter so that the 'CleanSpace' text faces up (in the same direction as the keypad) and push the filter towards the Power Unit until you hear a click. The filter should be seated securely in place.

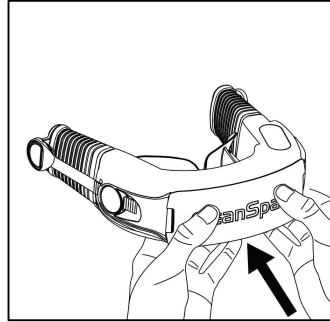
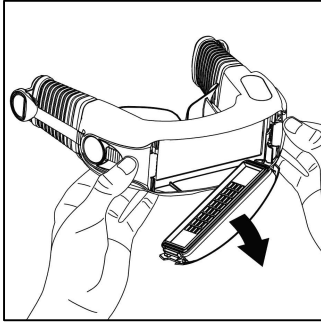

2.6. ACCESSORIES

2.6.1 PARTICULATE PRE-FILTER COVERALL

The CleanSpace Particulate Pre-Filter Coverall is an optional accessory used to cover the Power Unit and remove coarse particulates. The Pre-Filter Coverall should be changed after each use.

It may be useful in high dust environments to enhance the life of the particulate filter, as coarse particles are removed before entering the particulate filter. The Pre-Filter Coverall should be donned after fitting a Neck Support (if required).

The Pre-Filter Coverall can be removed by tearing it along the seam. This is useful in situations where the coverall has been used in more hazardous environments (e.g. asbestos, silica), as it allows it to be disposed of responsibly whilst maintaining the respiratory protection of the user.

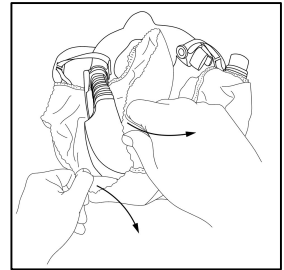
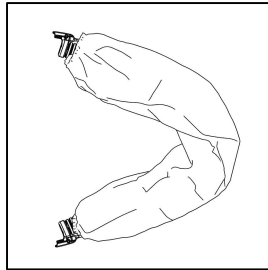
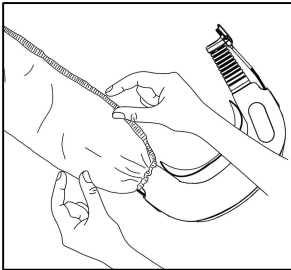

3. Before Donning the CleanSpace Respirator

3.1. CLEANSACE RESPIRATOR FIT

3.1.1 MASK SELECTION AND FIT

Before using your CleanSpace Respirator, you must determine the right mask for your face and know how to adjust the system to achieve a good fit. It is vital that your mask is the right size for your face and fits properly. Mask fit must be confirmed with a Protection Factor Test (Power On Fit Test).

The information below will help you to select the mask most likely to fit and may therefore save time. The 'Face Width' and 'Face Length' of a user are defined by the images below.

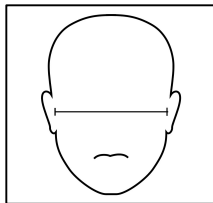

Face Width

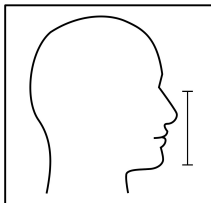

Face Length

Use the tables below to determine which CleanSpace Half or Full-Face Mask is likely to provide the best fit for your face.

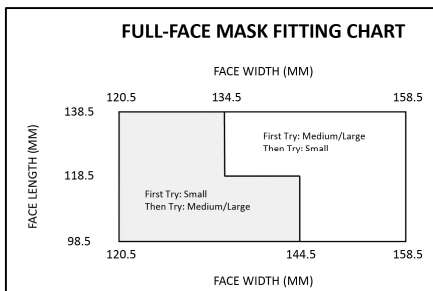
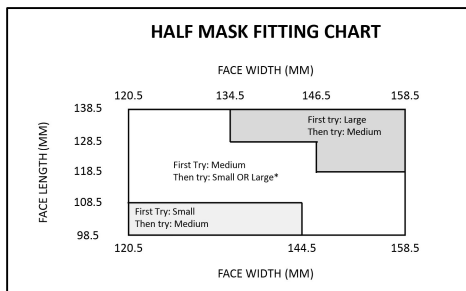

**If the medium mask fails initially, the mask fitting specialist will determine whether to try the small or the large mask next.*

3.1.2 NECK SUPPORT SELECTION AND FIT

Your CleanSpace Respirator is supplied with two sizes of Neck Support - Small ("S") and Medium ("M"). "S" is for people with smaller necks and heads while "M" is for those with medium sized heads and necks. Users for whom the "M" Neck Support does not provide enough room (both bellows are fully extended but mask is still too tight on face) should use the respirator without a Neck Support. This configuration provides extra room and is comfortable due to the curved design of the case. As a general rule, use the smallest size Neck Support that is comfortable.

Half Mask System

Selecting the right size of Neck Support is vital to achieving a good Half Mask fit. With the correct sized Neck Support, the Half Mask should achieve a good seal without using up all the travel in the respirator's bellow adjustment system. This gives an opportunity to adjust the respirator further for increased comfort and freedom of movement.

Full-Face Mask System

When used with a Full-Face Mask, the Neck Support is for comfort only and does not form part of the seal. Nevertheless, if your work involves vigorous movement, using a Neck Support may stabilise the Power Unit and reduce distracting movement.

3.1.3 HEAD HARNESS FIT

The Head Harness is a required component when using the CleanSpace Respirator Half Mask System. It is used to support the weight of the Power Unit and to ensure a good, comfortable fit. The harness has a rear strap that can be adjusted by the user to fit a variety of different head sizes. Users with a larger head should use the hole which 'elongates' the rear strap (left-hand arrow in the image below) while users with smaller heads should use the hole which 'shortens' the rear strap (right-hand arrow in the image below). When fitted correctly, the harness should sit comfortably on the crown of the head.

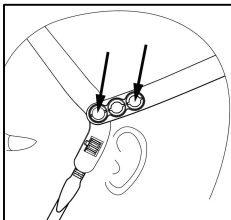

3.2. PRE-USE INSPECTION

Before each entry into a contaminated area, carry out a visual inspection of all components of your CleanSpace Respirator system. If parts are missing or damaged replace them only with approved parts before proceeding.

- **Check the POWER UNIT** for cracks, holes or other damage or missing parts. Do not use the device if there is any damage or misuse. Check both bellows for splits or holes. Check that the bellows have not become distorted as this may obstruct the air supply to the mask. Check the Neck Support (if required). Check that the battery has sufficient charge to complete the work period by pressing the Power Button. The Battery Charge Indicator light(s) will illuminate to indicate the approximate charge. A full charge is recommended.
- **Check the FILTER** carefully. The filter seal must be clean and free from damage of any kind. Examine the visible internal surfaces for any sign that dust has penetrated the media. If dust is found, do not use the filter. The body of the filter must be free of cracks or signs of damage. If any sign of impact or scratching is found, discard the filter. Fit the filter to the respirator (refer to Section 2.5).
- **Check the MASK** to ensure that there are no cracks, tears or dirt; check the mask is not distorted. Check the mask exhalation valve for damage or dirt build up. If it is dirty, remove any dirt, hairs or anything that could affect the seal of the valve against its seat. Check that the valve seat is clean. If the valve is damaged, replace it. If using a Full-Face Mask, ensure the Rain Cover is lowered before use.
- **Check the HEAD HARNESS** is intact, is not frayed or damaged and has good elasticity.

3.3. RECALIBRATION

This respirator contains a system for synchronizing with your breathing, regulating mask pressure and updating the operating altitude of the Power Unit. This system should be recalibrated if it experiences a change in temperature of more than 20°C, a change in altitude of more than 100m or before using the respirator for the first time. It is best practice to also recalibrate if the unit has been in storage and the storage temperature is not known. Steps to recalibrate:

1. Remove the filter and mask (if fitted) from the Power Unit.
2. With the respirator in STANDBY Mode (i.e. one or more Battery Charge Indicator lights on), press the Power Button and the Flow Test Button on the keypad at the same time.
3. When both the blue On Light and the red Filter Alarm Light illuminate, release both buttons.
4. Do not touch or move the respirator during the recalibration process.
5. After 5 seconds, the Power Unit will run and air will blow from the left-hand bellow for about 10 seconds.
6. When the airflow stops, recalibration is complete, and the Battery Charge Indicators will return to indicating battery charge status.
7. Refit the filter to the Power Unit.



You must recalibrate the internal pressure sensor any time that your CleanSpace Respirator is exposed to changes in temperature of more than 20°C, changes in altitude of more than 100m or before using the respirator for the first time. It is best practice to also recalibrate if the unit has been in storage, particularly if the storage temperature is not known.

3.4. FLOW TEST

The Flow Test checks that the CleanSpace Respirator can deliver a minimum flow of 120 l/min. This test should be completed before each entry into a contaminated area.

3.4.1 FLOW TEST PROCEDURE

1. Leave the filter in place.
2. Place the respirator flat on a table or other support.
3. Ensure the Power Unit is in STANDBY Mode (press the Power Button once if not). Press and release the Flow Test Button.
4. The respirator will automatically run the Flow Test. During the test, air will flow from the left-hand bellow.
5. After 2 seconds the respirator reports the test result using the Battery Charge Indicator lights on the keypad. Use the table below to interpret the indicators.

Flow Test Result	Meaning		Note
3 Solid Green Lights	PASS	Excellent (Flow > 180 l/min)	Flow Test 'pass' result will display for a few seconds. Power Unit will then switch to OFF Mode.
2 Solid Green Lights	PASS	Good	
1 Solid Green Light	PASS	Acceptable	
1 Red Flashing Filter Alarm Light & 3 Flashing Green Lights	FAIL	Fail (Flow < 120 l/min)	Reset by pressing the Power Button once. Power Unit will then switch to STANDBY Mode.

3.4.2 FAILED FLOW TEST

Do not use the respirator until a new filter has been fitted and/or the battery has been fully charged and the test has been repeated with a PASS result. If the respirator fails the test but the filter is new and the battery is fully charged, make sure the operating altitude is set correctly. The operating altitude can be set by recalibrating the Power Unit. If the respirator continues to fail the flow test, contact CleanSpace Technology and do not use the respirator until it has been evaluated.

Important: The Flow Test is not a battery charge test. Three Battery Charge Indicator lights means that, at the moment it is tested, the unit can deliver high flow. It does not mean the battery is fully charged. Check the battery charge separately. Refer to Section 2.2.3.

4. Donning the Half Mask CleanSpace Respirator

Locate your Power Unit, Half Mask, Neck Support and Head Harness. Make sure the Half Mask, Neck Support (if required) and Head Harness are the same size or setting that you used for your last successful fit test. Ensure a clean filter is fitted to the Power Unit.

Important: Read through this entire chapter before beginning to don the CleanSpace Respirator.

STEP 1 – FIT THE NECK SUPPORT TO THE POWER UNIT

The Neck Support has circular openings at each end which snap over buttons on the Power Unit case. Position the Neck Support in place against the buttons and then press firmly until the Neck Support clips securely into place.

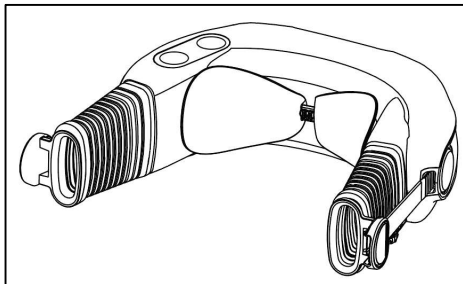
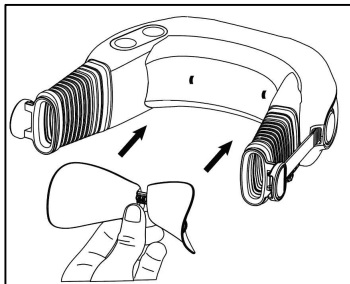

STEP 2 – FIT THE HEAD HARNESS TO THE HALF MASK

Connect the two side straps of the Head Harness to the circular clips located on the inside of the mask, ensuring that the harness strap with the front marker is facing forwards. Loosen the side straps as far as they will travel.

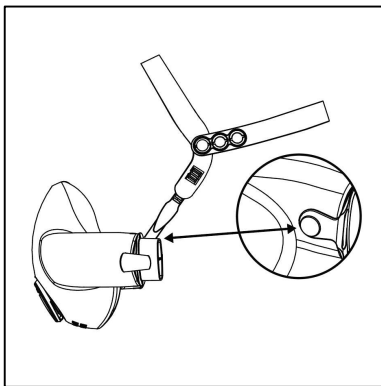

STEP 3 – FIT THE HALF MASK TO THE POWER UNIT

Ensure that the peak of the mask and the keypad on the Power Unit are both facing up. Bring the right-hand side of the Mask and Power Unit together until the AirClips click into place. Loosen the bellows as far as they will go by pressing the Adjust Buttons on each side of the Power Unit whilst gently extending the bellows away from the Power Unit.

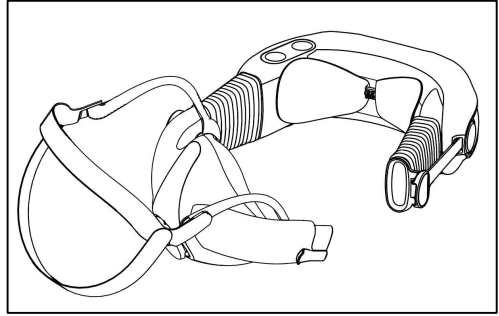
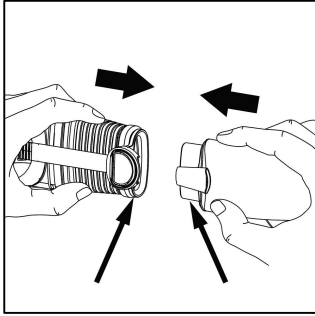

STEP 4 – SWITCH THE POWER UNIT TO STANDBY MODE

Press the Power Button once to switch the Power Unit to STANDBY Mode from OFF Mode. The Battery Charge Indicator should display the level of charge. The respirator should be fully charged before use.

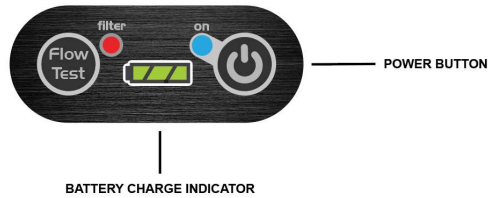

STEP 5 – DON THE RESPIRATOR

To don the respirator:

1. Drape the Power Unit around the back of the neck and connect the left-hand side of the Mask and Power Unit until the AirClips click into place.
2. Lift the mask onto your face and pull the Head Harness upwards and over the face until it sits comfortably on the crown of your head.
3. Breathe in, the Power Unit will automatically switch to ON Mode. If it doesn't, check that the respirator is in STANDBY Mode.
4. Locate the rear harness hook and clip it securely to the Power Unit Hoop.

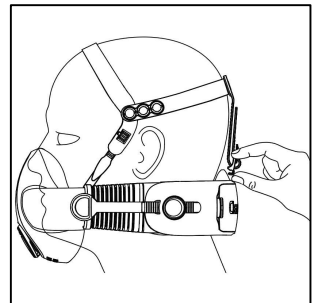
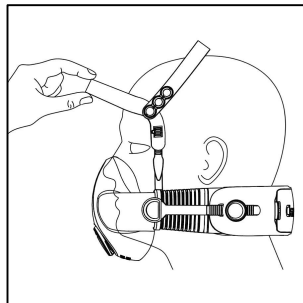
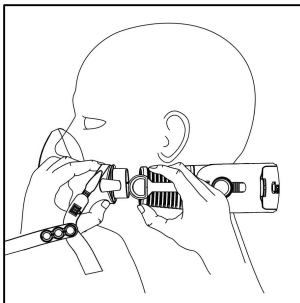

STEP 6 – ADJUST THE RESPIRATOR

If required, the CleanSpace Respirator can be adjusted after donning by either tightening the bellows or tightening the harness.

1. Tighten the bellows by placing one hand on the back of the Power Unit and one hand over the front of the mask. Push the Power Unit forwards and the mask backwards, tightening the fit. Ensure bellow adjustments are symmetrical. If the mask is too tight, loosen the bellows by pressing the Adjust Buttons.
2. Tighten the harness by pulling the side straps downwards. The harness can also be loosened if required by lifting the ratchet clips upwards and pulling the base of the side straps downwards.
3. Tighten the rear hook by pulling upwards on the back strap. The respirator should sit evenly and level.

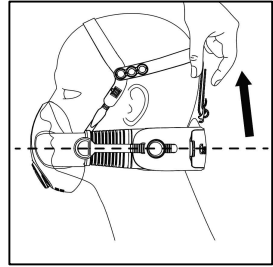
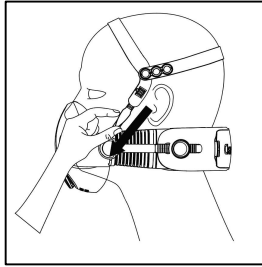
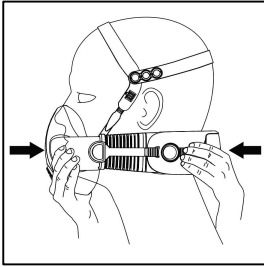

STEP 7 – COMPLETE A MASK SEAL CHECK

A mask seal check is used to ensure that an adequate seal is achieved each time the respirator is donned. Please note – due to changes in pressure, the Power Unit may switch between modes and the air may blow during this process. This is normal and will not affect the seal check.

To complete a seal check:

1. Unclip the left-hand AirClip while holding the Power Unit close to your head with your right hand.
2. Block the left-hand mask air inlet with your thumb.
3. Breathe in. You should not be able to draw any air into the mask. The mask should collapse inwards as you inhale, with no leaks. Listen for any squeaking or whistling noises which may indicate that air is leaking past the seal.
4. Hold your breath for approximately 5 seconds. The mask should stay collapsed against your face. If the mask seal slowly recovers (mask moves away from your face) there is a leak.
5. If there is a leak, readjust the mask, confirm the left-hand mask air inlet is completely blocked and repeat the seal check until no leakage is observed.
6. After passing the seal check, reconnect the left-hand side of the Mask and Power Unit, ensuring the AirClips click into place. Once reconnected, the respirator will either
 - a) Automatically switch to ON Mode.
 - b) If it is already in ON Mode, it will continue to operate as required.

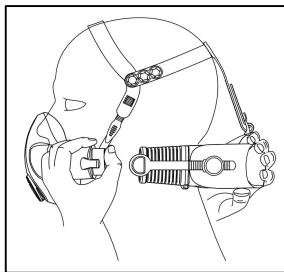

5. Donning the Full-Face Mask CleanSpace Respirator

Locate your Power Unit, Full-Face Mask and Neck Support. Make sure the Full-Face Mask and Neck Support (if required) are the same size or setting that you used for your last successful fit test. Ensure a clean filter is fitted to the Power Unit.

Important: Read through this entire chapter before beginning to don the CleanSpace Respirator.

STEP 1 – FIT THE NECK SUPPORT TO THE POWER UNIT

The Neck Support has circular openings at each end which snap over buttons on the Power Unit case. Position the Neck Support in place against the buttons and then press firmly until the Neck Support clips securely into place.

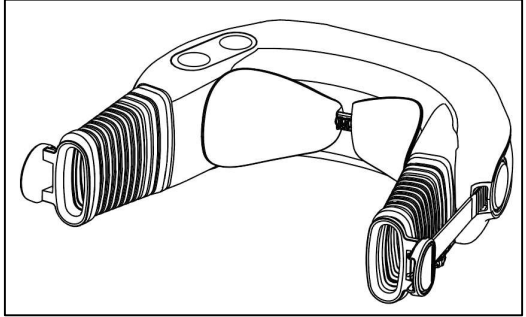
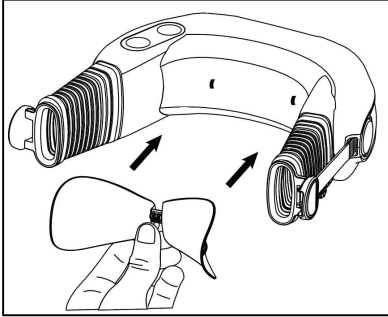

STEP 2 – DON THE FULL-FACE MASK

To don the Full-Face Mask:

1. Loosen all five (5) straps on the mask harness to their fullest extent. Hold the mask in one hand while you use your other hand to move the harness straps clear of the mask seal.
2. Place your chin in the cup of the mask face seal and then pull the harness up and over your head. Settle your face into the mask seal. Adjust the top strap so that the hanger for the back strap sits a couple of centimetres above your ears.
3. Gently tighten each harness strap in turn by pulling the strap rearward. Start with the bottom straps. As you pull each strap, use your other hand to steady the mask on your face.
4. Continue to adjust the straps until the mask face seal presses evenly on your face around its entire length.

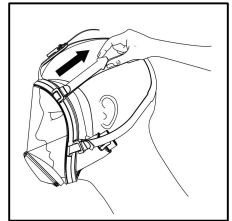
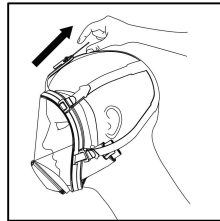
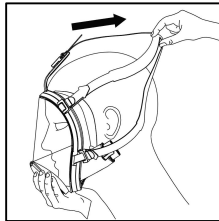
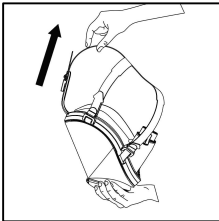

STEP 3 – COMPLETE A MASK SEAL CHECK

A mask seal check is used to ensure that an adequate seal is achieved each time the respirator is donned. To complete a seal check:

1. Block both mask air inlets with your thumbs.
2. Breathe in. You should not be able to draw any air into the mask. The mask should be drawn in towards your face as you inhale. Listen for any squeaking or whistling noises which may indicate that air is leaking past the seal.
3. Hold your breath for approximately 5 seconds. The mask should stay drawn in against your face. If the mask seal slowly recovers (mask moves away from your face) there is a leak.
4. If there is a leak, readjust the mask, confirm the mask air inlets are completely blocked and repeat the seal check until no leakage is observed.

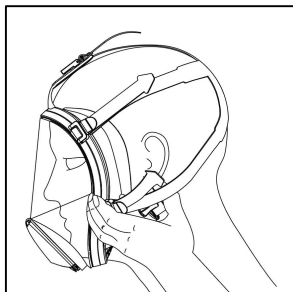

STEP 4 – SWITCH THE POWER UNIT TO STANDBY MODE

Press the Power Button once to switch the Power Unit to STANDBY Mode from OFF Mode. The Battery Charge Indicator should display the level of charge. The respirator should be fully charged before use.

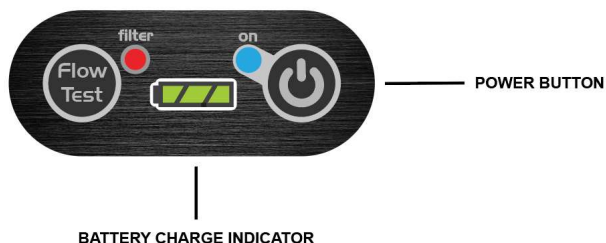

STEP 5 – DON THE RESPIRATOR

To don the respirator:

1. Loosen the bellows as far as they will go by pressing the Adjust Buttons on each side of the Power Unit whilst gently extending the bellows away from the Power Unit.
2. Drape the Power Unit around the back of your neck and connect the right-hand side of the Mask and Power Unit until the AirClips click into place.
3. Connect the AirClips on the left-hand side.
4. Breathe in, the Power Unit will automatically switch to ON Mode. If it doesn't, check that the respirator is in STANDBY Mode.
5. Locate the rear harness hook and clip it securely to the Power Unit Hoop.

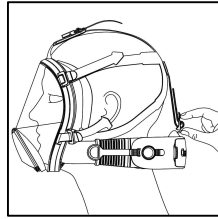
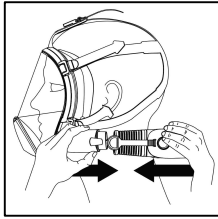

STEP 6 – ADJUST THE RESPIRATOR

If required, the CleanSpace Respirator can be adjusted by tightening the bellows or the harness back strap.

1. Tighten the bellows by placing one hand on the back of the Power Unit and one hand over the front of the mask. Push the Power Unit forwards and the mask backwards, tightening the fit. Ensure bellow adjustments are symmetrical. If the mask is too tight, loosen the bellows by pressing the Adjust Buttons.
2. Tighten the rear hook by pulling upwards on the back strap. The respirator should sit roughly level.

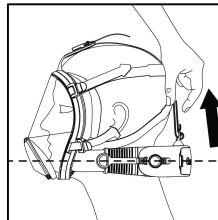
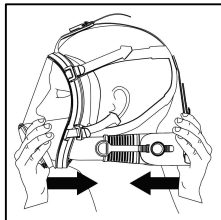

6. The Contaminated Area

6.1. HUMAN FACTOR CONSIDERATIONS

6.1.1 NOISY ENVIRONMENTS

In most noisy environments, the respirator alarms are still clearly audible to the user. However, if there is a chance you will not hear them, you must take the following extra precautions.

- Do not enter the contaminated area unless all three (3) green Battery Charge Indicator lights are illuminated.
- Do not work in a high noise area for more than four (4) hours. At the end of four (4) hours, leave the contaminated area and check;
 - the Filter Alarm Light is not illuminated; AND
 - all three (3) green Battery Charge Indicator lights are still illuminated.
- If two (2) or fewer green Battery Charge Indicator lights are illuminated, recharge the CleanSpace Respirator until three (3) solid green lights are displayed.
- If the red Filter Alarm Light is illuminated, change the filter.
- Be particularly aware of difficulty breathing or of the powered airflow stopping. If either of these things occur, exit the contaminated area immediately.

6.1.2 COMMUNICATION

The following recommendations are suggested to aid communication whilst wearing a CleanSpace Respirator.

- Speak 30% louder in volume.
 - Truncate sentences – shorten communication to ensure it is clear and concise.
 - Use closed loop communication – exchange information, acknowledge receipt of that information and confirm the recipient has interpreted the information correctly.
-

6.2. ENTERING THE CONTAMINATED AREA

Prior to entering the contaminated area, complete the inspections and checks listed in these User Instructions.

- Ensure a mask seal check has been completed and the motor is responding to your breathing.
- Familiarize yourself with the Adjust Buttons and the Mask Release Buttons.
- Check no alarms are sounding or flashing. If your work environment is noisy, you may be unable to hear the alarms. In this case you must follow the special precautions set out in Section 6.1.
- If additional PPE is required, ensure this is donned also.
- Enter the contaminated area.



Do not remove the respirator until you have vacated the contaminated area. If you have an acute and spontaneous health episode (i.e. experiencing dizziness) and believe removing the respirator while you leave the contaminated area may help, remove the respirator with caution.

6.3. EXITING THE CONTAMINATED AREA

Leave the contaminated area immediately if any of the following conditions occur:

- The Filter Change Alert, Low Battery Alarm or the Filter Absent Alarm triggers.
- Any part of the system becomes damaged.
- Airflow into the mask decreases or stops.
- Breathing becomes difficult.
- You feel dizzy or your vision is impaired.
- You smell or taste contaminants.
- Your face, eyes, nose or mouth experience irritation.
- You suspect the concentration of environmental contaminants has reached levels at which this respirator may no longer provide protection.
- Oxygen/carbon dioxide levels change such that PAPRs should no longer be worn.

Follow the exiting and decontamination procedures as documented in the workplace Respiratory Protection Program. Follow those procedures with the instructions below when removing the respirator.

6.4. DOFFING THE HALF MASK RESPIRATOR

To doff the Half Mask CleanSpace Respirator:

1. Unclip the rear hook of the Head Harness from the Power Unit Hoop.
2. Slide the harness forward over your head, toward the nose of the mask.
3. Locate one of the Mask Release Buttons on either side of the respirator.
4. Press the button and gently pull the Power Unit away from the mask.
5. Remove the respirator from your face.

After the Power Unit is removed, the air will continue to blow for approximately 5 seconds before automatically switching to STANDBY Mode when no breathing is detected. There is no need to turn the respirator off, after three (3) minutes in STANDBY Mode, the respirator will automatically switch to OFF Mode.

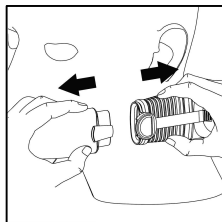
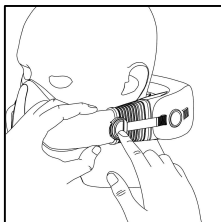

6.5. DOFFING THE FULL-FACE MASK RESPIRATOR

To doff the Full-Face Mask CleanSpace Respirator:

1. Unclip the rear hook of the harness from the Power Unit Hoop.
2. Locate the Mask Release Buttons on either side of the respirator.
3. One side at a time, press the buttons and gently pull the Power Unit away from the mask. After the Power Unit is removed, the air will continue to blow for approximately 5 seconds before automatically switching to STANDBY Mode when no breathing is detected. There is no need to turn the respirator off, after three (3) minutes in STANDBY Mode, the respirator will automatically switch to OFF Mode.
4. To remove the Full-Face Mask, loosen the harness straps and then remove the mask from your face.

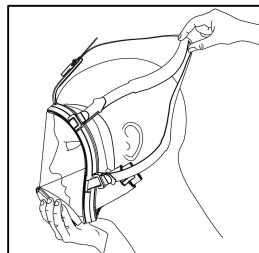
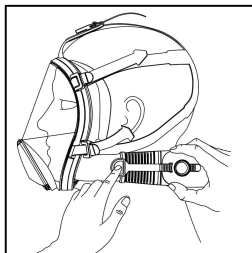
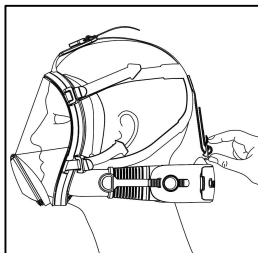

7. Care and Cleaning

7.1. CLEANING

We recommend that you clean your respirator after every use. CleanSpace Respirator components should be cleaned separately. Determine the method most appropriate to your cleaning requirements. If using a wipe, refer to the *Compatible Cleaning and Disinfecting Agents Supplement* available from CleanSpace Technology at cleanspacetechnology.com.

Important: The methods to clean the equipment (outlined below) are not a disinfection or sterilization protocol. If disinfection or sterilization is required, contact CleanSpace Customer Service at sales@cleanspacetechnology.com.

7.1.1 HALF MASK

Determine the method most appropriate to your cleaning requirements. If using a wipe, refer to the chemical agent and disinfectant supplement information available from CleanSpace Technology.

If washing the Half Mask, remove the valve cover. To do this, locate the snap feature on the cover that secures it to the valve seat. This feature is located on the bottom edge of the valve seat. Using your thumb nail or a small blunt object such as a pen, press on the snap until the cover springs free of the valve seat as shown in the image below. Then, wash the mask (including the exhalation valve leaf and cover) thoroughly with a mild detergent in warm water (less than 50°C). Rinse well in warm running water to ensure any residue from the cleaning solution has been removed.

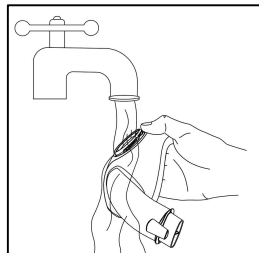
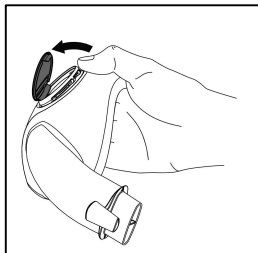

After cleaning, allow the mask to air dry in a clean environment (valve up to prevent pooling) or hand dry with a clean, lint-free cloth. Do not dry the mask by exposing directly to heat. Before use, ensure that the exhalation valve leaf is properly seated against the valve body and operates freely. Reinstall the valve cover. Visually check the valve leaf again after the cover has been installed to ensure the valve leaf is completely sealed against the valve body.

7.1.2 FULL-FACE MASK

Determine the method most appropriate to your cleaning requirements. If using a wipe, refer to the chemical agent and disinfectant supplement information available from CleanSpace Technology.

Before washing the Full-Face Mask, remove the inner mask (pinch snaps together and pull the top of the inner mask back) and raise the Rain Cover to improve access. Then, wash the Full-Face Mask (including the exhalation valve leaf and Rain Cover) and the inner mask thoroughly with a mild detergent in warm water (less than 50°C). Rinse well in warm running water to ensure any residue from the cleaning solution has been removed.

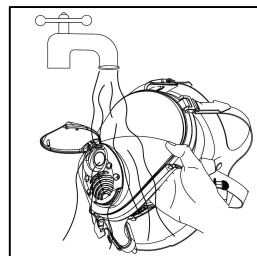
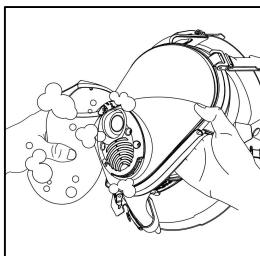
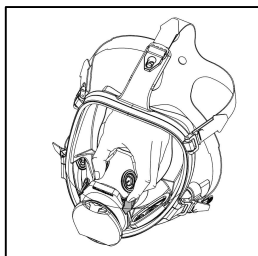

After cleaning, allow the mask to air dry in a clean environment (valve up to prevent pooling) or hand dry with a clean, lint-free cloth. Do not dry the mask by exposing directly to heat. Before use, ensure that the exhalation valve leaf operates freely, the inner mask has been refitted and the Rain Cover has been lowered.



Never dry the mask or exhalation valve with a cloth that may leave behind lint. Lint contamination of the exhalation valve may cause it to leak, resulting in overexposure to contaminants and lead to sickness.

7.1.3 POWER UNIT

Use cleaning wipes or a cloth dampened with cleaning agent to wipe down the outside of the Power Unit. After cleaning, use a clean cloth to remove any residue from the cleaning agent. Allow the Power Unit to air dry in a clean environment or dry the Power Unit using a clean, lint-free cloth.

Using a Cleaning and Storage Plug, higher level cleaning is available for the Power Unit. Please visit the resources section of the CleanSpace website for more information at cleanspacetechnology.com.



CleanSpace Power Units contain a battery, sensitive electronics, and a motor. NEVER immerse the Power Unit in water.

7.1.4 FILTER

CleanSpace particulate filter media cannot be cleaned. The filter media is contained within a filter case. Dispose of the filter responsibly when a change is required. Refer to Section 2.5 for more information.

7.1.5 HEAD HARNESS AND NECK SUPPORT

The Head Harness and Neck Supports can be cleaned using the methods described for the CleanSpace Masks.

7.1.6 PARTICULATE PRE-FILTER COVERALL

The CleanSpace Particulate Pre-Filter Coverall (PAF-0058) cannot be cleaned. Dispose of it responsibly when a change is required.

7.2. STORAGE

The respirator and additional components should be stored under the following conditions when not being used.

- Relative Humidity: 0% to 75%.
- Temperature: 10°C to 30°C.

Out of direct sunlight, in a clean, dry environment.

7.3. RECALIBRATION

This respirator contains a system for synchronizing with your breathing, regulating mask pressure and updating the operating altitude of the Power Unit. This system should be recalibrated if it experiences a change in temperature of more than 20°C, a change in altitude of more than 100m or before using the respirator for the first time. It is best practice to also recalibrate if the unit has been in storage, particularly if the storage temperature is not known. Refer to Section 3.3 for the recalibration procedure.

7.4. SERVICING

It is the purchaser's responsibility to ensure that CleanSpace respirators and components are regularly maintained to an operational standard. CleanSpace recommends annual servicing of CleanSpace respirators by an accredited CleanSpace technician. For more information go to cleanspacetechnology.com.

8. List of Components

Type	Description	Product Code
Power System	Power System – CST PRO	CST1000
	Power System – CST ULTRA	CST1010
Power Unit	Power Unit – CST PRO	CST1002
	Power Unit – CST ULTRA	CST1012
Mask	Half Mask – Small	CST1014
	Half Mask – Medium	CST1015
	Half Mask – Large	CST1016
	Half Mask with harness – Small	CST1034
	Half Mask with harness – Medium	CST1035
	Half Mask with harness – Large	CST1036
	Full Face Mask – Small	CST1017
Filter	High-Capacity Particulate Filter	CST1004
	Standard Particulate Filter	CST1005
	ABEK1 TM3 Combined Filter (EU/UK only)	CST1006
	ABEK1 P3 Combined Filter (AUS/NZ only)	CST1007
	A2 TM3 Combined Filter (EU/UK only)	CST1008
	ABE1 TM3 Combined Filter (EU/UK only)	CST1027
	A1 TM3 Combined Filter (EU/UK only)	CST1028
Neck Support	Neck Support – Small	CST1019
	Neck Support – Medium	CST1020
Head Harness	Head Harness	CST1021
Accessories	Universal Charger	PAF-1101

For information on the full range of available products, please refer to the CleanSpace website at cleanspacetechnology.com.

9. Specifications

Operation	
Weights	System: 600g (Power Unit, filter, Half Mask (M), Neck Support (M), Head Harness). Half Masks (with Head Harness): 145g to 175g, Full-Face Masks: 720g to 735g. Head Harness: 30g.
Air Flow (Breath Responsive)	Minimum: 120 l/min, Maximum: 230 l/min. <i>Dependent on filter type, filter loading, altitude and battery condition.</i>
Operating Temperature Range	Minimum: -10°C, Maximum: 45°C. <i>The CleanSpace Respirator will shut down when battery temperature is greater than 60°C or less than -10°C.</i>
Operating Humidity Range	Zero to 90%, non-condensing.
Operating Altitude Range	Minimum: Approx. -1000m, Maximum: Approx. 4200m.
Operating Run Time	Up to approximately 14 hours. <i>Run time is strongly influenced by filter type, filter loading, mask seal, work rate, altitude and other factors. Run times may vary widely.</i>
Ingress Protection	IP65 (CleanSpace ULTRA only) – dust tight, protected against powerful water jets.
Battery	
Charger	Input: 100 – 240VAC, 50 – 60 Hz. Output: 14.7 VDC, 24 Watts
Charging Temperature Limits	0°C to 35°C. <i>The battery will not accept charge outside of this range.</i>
Optimal Storage Conditions	10°C to 30°C & 0% to 75% relative humidity. <i>Out of direct sunlight, in a clean, dry environment.</i>
Battery (Type/Capacity)	Lithium-Ion – 11.1V, 1850 mAh, 20.54Wh.
Recharge Time	2 hours (to 95%).
Alarms & Alerts	
Filter Change Alert	Triggers when the filter has exceeded service limits and needs to be changed. <i>Audible alert: 2 beeps repeated every second, 75dB(A) at ear.</i> <i>Visual alert: Red Filter Alarm Light flashes.</i>
Low Battery Alarm	Triggers when the remaining operating time is approximately 15 minutes. <i>Audible alarm: 3 beeps, repeated every second, 75dB(A) at ear.</i> <i>Visual alarm: Single green Battery Charge Indicator light flashes.</i>
Filter Absent Alarm	Triggers when the respirator detects that there is no filter present. <i>Audible alarm: Constant, continuous beep, 75dB(A) at ear.</i> <i>Visual alarm: Red Filter Alarm Light flashes.</i>

10. Warranty

This product has been manufactured using quality parts and processes. CleanSpace Technology Pty Ltd warrants that the product is free from defective workmanship and parts for a period of two (2) years from the date of original purchase provided the product has been used, cleaned and maintained in accordance with these instructions and CleanSpace Technology's recommendations. This warranty does not include consumable parts, such as filters and face masks, which must be replaced regularly by the user. Consumable parts are warranted up to the point of use, provided they have been stored correctly and are within their expiry date.

This warranty does not cover:

- Where the product has been used for industrial purposes outside the recommendations of CleanSpace Technology Pty Ltd;
- Where damage has been caused by misuse, neglect, accident, or excessive wear and tear.

Any claim under this warranty must be made within two (2) years of the date of purchase of the product. All warranty claims must be made by returning the defective product to your supplier together with the proof of purchase. The purchaser is responsible for all freight. In the event that any part of the product is found by CleanSpace Technology to be defective, CleanSpace Technology will either repair or at its discretion replace the faulty part.

This warranty is given by:

CleanSpace Technology Pty Ltd

ABN 24 146 453 554,

Unit 5. 39 Herbert Street

St. Leonards, NSW 2065 Australia;

T: +61 2 8436 4000

E: sales@cleanspacetechnology.com

This warranty is provided in addition to other rights and remedies you have under law. You are entitled to replacement or refund for a major failure. You are also entitled to have the goods repaired or replaced if the goods fail to be of acceptable quality and the failure does not amount to a major failure.

Disclaimer:

Whilst CleanSpace Technology has made every effort to ensure that the details and information given in both our printed and online publications are accurate at the time of issue, full technical specifications are not necessarily included. Furthermore, CleanSpace Technology has a policy of continuous improvement and the right is reserved to alter details and information as the need arises. Accordingly, the Customer should check any details and information they wish to rely on with CleanSpace Technology at the time of purchase. CleanSpace Technology cannot accept liability in respect of any errors or omissions herein contained or for any loss or damage malfunction or consequential loss arising from reliance upon our publication.

The Customer will be responsible for any risk to health or safety from goods in the Customer's possession and/or control. The Customer's attention is drawn to the fact that statutory regulations and recognized codes of practice exist covering the use and handling of some goods (including safety products). The Customer must ensure that persons who use the goods receive adequate training and safety literature.

©2023 CleanSpace Technology Pty Ltd. All rights reserved.

No page or part of these User Instructions may be reproduced in any form without written permission of the copyright owner shown above. CleanSpace Technology reserves the right to correct typographical errors. All information is correct at the time of going to print.

S008-7012 Rev 1, 14th April 2023

Released on Change Note ECN1860
