

PRODUCT CODE: PAF-0034, PAF-0060 and PAF-0070

PRODUCT NAME: CleanSpace™ PAPR Power Units



STEPS TO CONDUCT AN AIR FLOW RATE TEST

This test checks that the power unit air flow and can deliver the Manufacturer's Minimum Design Flow of 120 litres/minute. Follow the steps below to conduct the air flow test.

1. Fit the yellow Flow Test Cap to the left bellow. See Figure 1.

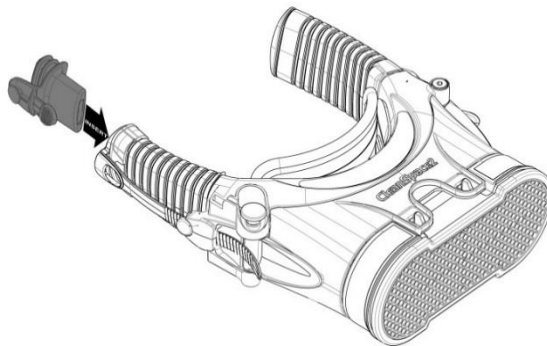

To avoid unnecessary filter changes, it is important to fit the Flow Test Cap to the **LEFT** bellow.

No air flows out of the right bellow. Fitting the Flow Test Cap to the right bellow will result a **FAIL** result, even if the filter is clean and battery fully charged.

Figure 1 - Flow Test (Note – respirator shown here with Filter Adaptor fitted, but test is the same regardless of respirator configuration)

2. Make sure nothing is blocking the Flow Test Cap or the filter inlet. Place CleanSpace Ultra flat on a table or other support.
3. Press and release the button marked “Flow Test”
4. CleanSpace Ultra automatically runs the Flow Test. The motor will run fast and air will be discharged from the Flow Test Cap.
5. After 2 seconds CleanSpace Ultra reports the result of the test using the LEDs on the keypad. Use the table below to interpret the LEDs.

LIGHTS	DEFINITION
3 LEDs:	PASS (Excellent: flow >180 l/min)
2 LEDs:	PASS (Good)
1 LED:	PASS (Acceptable)
ALL LEDs FLASH	FAIL (Flow <120 l/min) Do NOT use CleanSpace PAPR. REPLACE THE FILTER and ensure the BATTERY IS FULLY CHARGED. Before use repeat the airflow test for a PASS result. Reset the respirator by pressing the Power button. Repeat the flow test. If filter is new and battery fully charged AND CleanSpace PAPR™ fails the test, contact PAFtec Australia and do not use.